

GRAVITY ROLLER SILO QUOTATION WORKSHEET

Company _____ Date _____
 Contact _____ Quote Due _____ Desired Delivery _____
 Phone No. _____ Contact Email _____ State _____
 Omni Sales Contact _____ Quote #: _____
 Quantity _____

Product Specs:

Max:
 - Width (inches): _____ Length (inches): _____
 - Height (inches): _____ Weight (lbs): _____
 - Diameter (inches): _____
 Min:
 - Width (inches): _____ Length (inches): _____
 - Height (inches): _____ Weight (lbs): _____
 - Diameter (inches): _____
 Description: _____
 Max. Qty.: _____ Total Live Load: _____
 Temperature
 -Environment: _____
 -Product: _____

Method of Conveying:

Accumulation Transportation

Other: _____

Between Frame: _____

Conveyor Construction:

Infeed Height: _____
 Discharge Height: _____
 Elevation Change: _____
 Center Line Diameter: _____

Model:

Roller Dual-Roller
 Taper Rollers Skatwheel

Construction Style:

Welded
 Painted Powder Coated
 Epoxy Painted
 Color / RAL: _____
 Stainless Steel
 Bolt-Together
 Painted Powder Coated
 Color RAL: _____
 Galvanized Stainless Steel
 Aluminum

Sides Guides:

Style:
 Skatwheel Roller Fixed
 Location:
 Inside Outside Both

Infeed/Discharge Orientation (Mark One)

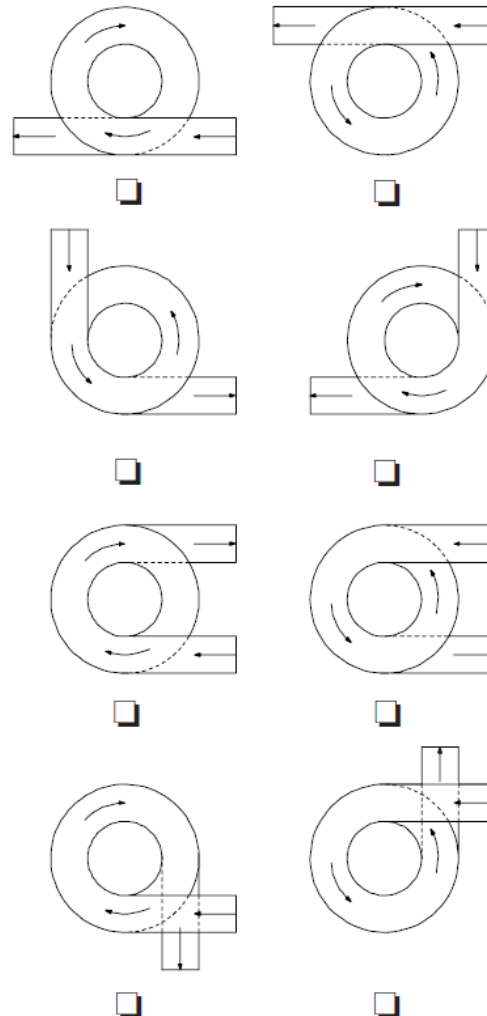

Support Structure:

H-Style Center Structure

Approval Drawing Required: Yes No