

BELT CONVEYOR QUOTATION WORKSHEET

Company _____ Date _____
 Contact _____ Quote Due _____ Desired Delivery _____
 Phone No. _____ Contact Email _____ State _____
 Omni Sales Contact _____ Quote # _____
 Quantity _____ Model Number _____

Product Specs:

Max:
 - Width (inches): _____ Length (inches): _____
 - Height (inches): _____ Weight (lbs): _____
 Min:
 - Width (inches): _____ Length (inches): _____
 - Height (inches): _____ Weight (lbs): _____
 Description: _____
 Max. Qty.: _____ Total Live Load: _____
 Temperature
 -Environment: _____
 -Product: _____

Belt:

Belt Width _____ Lace _____
 Belt Type _____

Conveyor Orientation:

Horizontal Incline Decline

A = ____' - ____" Horiz. OAL

B = ____' - ____" TOB

C = ____' - ____" TOB

D = ____' - ____" Elevation Change

E = ____' - ____" Nose-Over

F = ____' - ____" Power Infeed (Slaved)

G = ____ Deg. Approx. (Ref.)

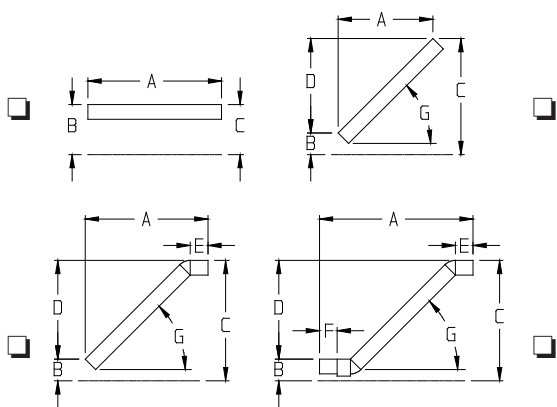

Support Type:

Legs Ceiling Supports Portable None

Approval Drawing Required: Yes No

Conveyor Type:

- Slider Bed
- Roller Bed
 - 1.9 x 16 GA. 1.9 x .145 W. 2 1/2 x 11 GA.
 - Other: _____ Roller C/C: _____
- V-Guided
 - Cleated Height: _____ C/C: _____
- Trough

Conveyor Construction:

- Welded
 - Painted Epoxy Painted
 - Powder Coated Color RAL: _____
- Bolt-Together Galvanized

Drive Type:

- Under Hung Shaft Mount Side Mount
- Over Top _____ " Clearance
- Motorized Drive Pulley

Drive Location:

- Discharge End Center Right Hand Drive
- Other _____ One Direction Product Flow
- Bi-Direction Product Flow

Customer Requested Horsepower: _____

Speed: F.P.M.: _____ Fixed Variable (10:1 Ratio)

- AC Speed Controller DC Speed Controller
- Mechanical Variable Speed Adjustment None

Plant Voltage:

- 110V Single Phase 460V Three Phase
- 220V Single Phase 208V Three Phase
- 220V Three Phase 575V Three Phase

Other: _____

