

LITHIUM-ION BATTERY RECYCLING

NO: 950



THE APPLICATION: Conveying Lithium-ion batteries into a shredding system

THE PRODUCT: Chain Driven Live Roller Conveyor with custom discharge transition

THE INDUSTRY: Lithium-ion battery materials and recycling

THE NEED: A leading Lithium-ion battery materials manufacturer opened a new facility, which required a solution to convey batteries into their shredding system, and needed the equipment to be delivered within 30 days upon receipt of order.

THE SOLUTION: Omni Metalcraft Corp. provided (3) 20' lanes of Chain Driven Live Roller Conveyor, with a custom discharge transition that integrated into other supplementary equipment. Lithium-ion battery modules were loaded onto the system, and successfully conveyed to additional supplementary equipment. The system was designed, manufactured, and shipped in less than 30 days of the order being received.

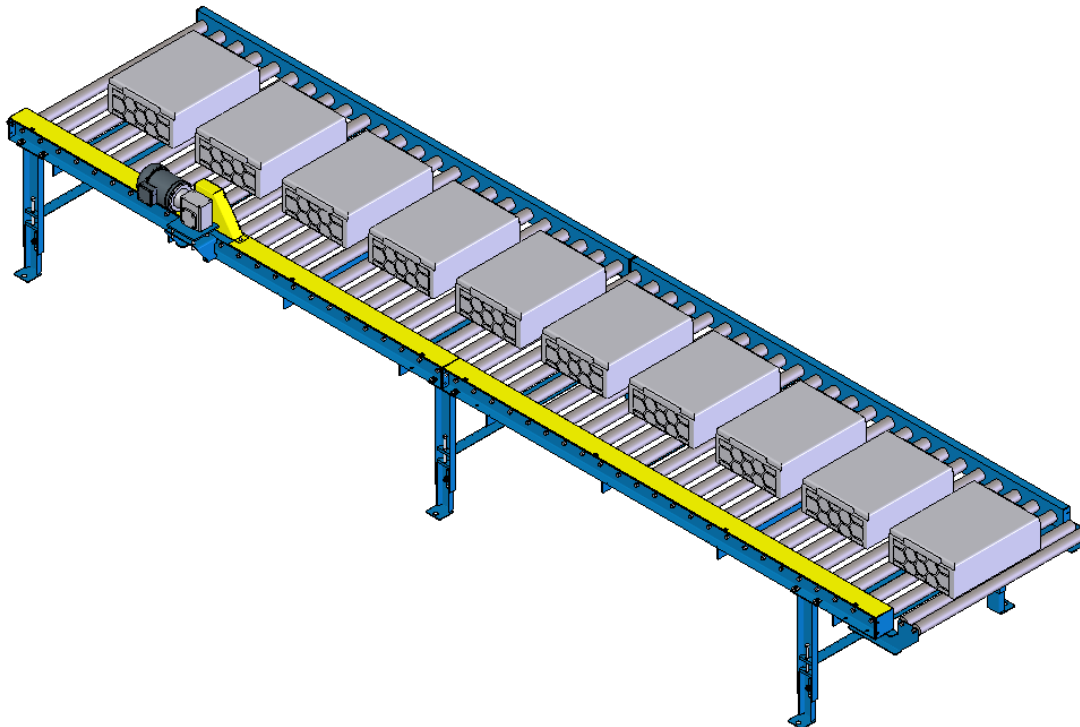

P.O. Box 352 ■ Alpena, Michigan 49707
Phone 989.358.7000
Fax 989.358.7020
info@omni.com
www.omni.com

OMC_05302023 - Solution Spotlight 950