

## 102229-GP

Load Capacity	425 lbs
Temp. Range	-40°F to 250°F

### Features

- Unground, non-precision
- Stamped metal construction
- Zinc plated mild steel
- Full ball compliment
- Front polymer seal
- Front and rear shields
- Replaceable
- Grease packed
- Regreaseable

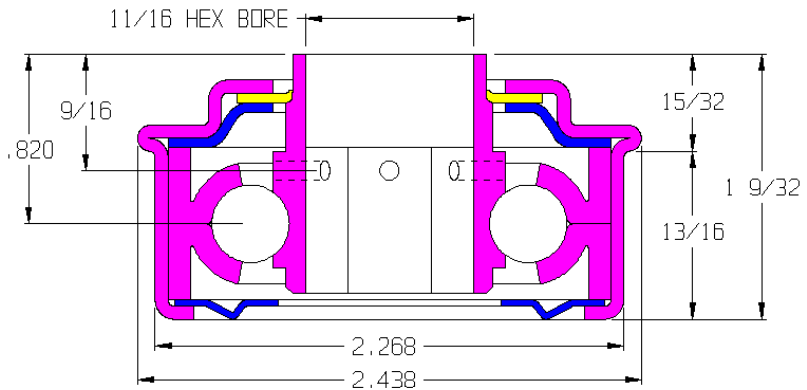

### Application Info

A very good all-around bearing. Recommended for mid-sized loads at slower speeds. A metal shield ring supports a polymer sealing ring to hold out small amounts of large particle debris. A hole through the inner race allows the bearing to be regreased through the axle. Bearings that are regularly regreased can withstand very high levels of debris without damage. The bearing is lubricated with grease and can be used in powered applications as well as gravity applications. The grease adds rotational drag and is not recommended for gravity applications with very light products.

### Similar Bearings

- 102318-GP is unflanged.
- 102041-GP is not regreaseable.

