

102051-O

Load Capacity	150 lbs
Temp. Range	-40°F to 140°F

Features

- Unground, non-precision
- Stamped metal construction
- Zinc plated mild steel
- Full ball compliment
- Front labyrinth shield
- Replaceable
- Lightly oiled

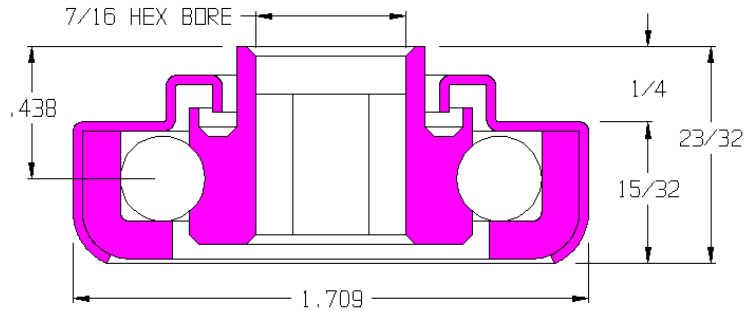

Application Info

Recommended for gravity conveyor applications. Overlapping parts of the bearing housing create a labyrinth shield that helps prevent debris from getting inside the bearing, without creating rotational drag. This is most effective against large debris in small amounts. Large amounts of debris can get lodged in the labyrinth, especially when moisture is present. Not recommended for dusty environments.

Similar Bearings

- 102051-GP is grease packed.
- 102042-O does not have a labyrinth shield.

